

## Features

- ◆ Low On-Resistance
- ◆ Fast Switching
- ◆ 100% Avalanche Tested
- ◆ Repetitive Avalanche Allowed up to Tjmax
- ◆ Lead-Free, RoHS Compliant

## Description

VS4020AS designed by the trench processing techniques to achieve extremely low on-resistance. Additional features of this design are a 150°C junction operating temperature, fast switching speed and improved repetitive avalanche rating . These features combine to make this design an extremely efficient and reliable device for use in Motor applications and a wide variety of other applications.

$V_{DS}$	40	V
$R_{DS(on),Typ}$	6.0	mΩ
$I_D$	18	A

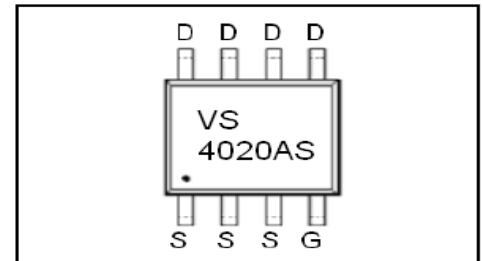

## Absolute Maximum Ratings

Stresses beyond those listed under "Absolute Maximum Ratings" may cause permanent damage to the device. These are stress ratings only; and functional operation of the device at these or any other condition beyond those indicated in the specifications is not implied. Exposure to absolute-maximum-rated conditions for extended periods may affect device reliability. The thermal resistance and power dissipation ratings are measured under board mounted and still air conditions. Ambient temperature (TA) is 25°C, unless otherwise specified.

Symbol	Parameter	Rating	Unit
<b>Common Ratings (Tc=25°C Unless Otherwise Noted)</b>			
VGS	Gate-Source Voltage	±20	V
$V_{(BR)DSS}$	Drain-Source Breakdown Voltage	40	V
ESD	Human Body Mode	±800	V
T <sub>J</sub>	Maximum Junction Temperature	150	°C
T <sub>STG</sub>	Storage Temperature Range	-55 to 150	°C
I <sub>S</sub>	Diode Continuous Forward Current	T <sub>C</sub> =25°C 18	A
<b>Mounted on Large Heat Sink</b>			
I <sub>DM</sub>	Pulse Drain Current Tested (Silicon Limit) ①	T <sub>C</sub> =25°C 72	A
I <sub>D</sub>	Continuous Drain current@VGS=10V	T <sub>C</sub> =25°C 18	A
P <sub>D</sub>	Maximum Power Dissipation	T <sub>C</sub> =25°C 2.5	W
		T <sub>C</sub> =75°C 2.0	W
R <sub>θJA</sub>	Thermal Resistance-Junction to Ambient	40	°C/W

**Typical Electrical Characteristics**

Symbol	Parameter	Condition	Min.	Typ.	Max.	Unit
<b>Static Electrical Characteristics @ T<sub>J</sub> = 25°C (unless otherwise stated)</b>						
V <sub>(BR)DSS</sub>	Drain-Source Breakdown Voltage	V <sub>GS</sub> =0V, I <sub>D</sub> =250μA	40	--	--	V
I <sub>DSS</sub>	Zero Gate Voltage Drain Current(Tc=25°C)	V <sub>DS</sub> =32V, V <sub>GS</sub> =0V	--	--	1	μA
	Zero Gate Voltage Drain Current(Tc=125°C)	V <sub>DS</sub> =32V, V <sub>GS</sub> =0V	--	--	100	μA
I <sub>GSS</sub>	Gate-Body Leakage Current	V <sub>GS</sub> =±20V, V <sub>DS</sub> =0V	--	--	±100	nA
V <sub>GS(TH)</sub>	Gate Threshold Voltage	V <sub>DS</sub> =V <sub>GS</sub> , I <sub>D</sub> =250μA	1.0	2.0	2.5	V
R <sub>DS(ON)</sub>	Drain-Source On-State Resistance①	V <sub>GS</sub> =10V, I <sub>D</sub> =10A	--	6.0	7.5	mΩ
R <sub>DS(ON)</sub>	Drain-Source On-State Resistance①	V <sub>GS</sub> =4.5V, I <sub>D</sub> =8A	--	7.5	8.5	mΩ
<b>Dynamic Electrical Characteristics @ T<sub>J</sub> = 25°C (unless otherwise stated)</b>						
C <sub>iss</sub>	Input Capacitance	V <sub>DS</sub> =20V, V <sub>GS</sub> =0V, f=1MHz	--	2250	--	pF
C <sub>oss</sub>	Output Capacitance		--	320	--	pF
C <sub>rss</sub>	Reverse Transfer Capacitance		--	195	--	pF
Q <sub>g</sub>	Total Gate Charge	V <sub>GS</sub> =10V	--	42	--	nC
		V <sub>GS</sub> =4.5V	--	25	--	nC
Q <sub>gs</sub>	Gate-Source Charge	V <sub>DS</sub> =20V, I <sub>D</sub> =10A, V <sub>GS</sub> =10V	--	7	--	nC
Q <sub>gd</sub>	Gate-Drain Charge		--	9.5	--	nC
<b>Switching Characteristics</b>						
t <sub>d(on)</sub>	Turn-on Delay Time	V <sub>DD</sub> =20V, I <sub>D</sub> =9A, R <sub>G</sub> =6.8Ω, V <sub>GS</sub> =10V	--	16.5	--	nS
t <sub>r</sub>	Turn-on Rise Time		--	17.5	--	nS
t <sub>d(off)</sub>	Turn-Off Delay Time		--	24	--	nS
t <sub>f</sub>	Turn-Off Fall Time		--	16	--	nS
<b>Source- Drain Diode Characteristics @ T<sub>J</sub> = 25°C (unless otherwise stated)</b>						
I <sub>SD</sub>	Source-drain current(Body Diode)	T <sub>c</sub> =25°C	--	--	16	A
V <sub>SD</sub>	Forward on voltage	I <sub>SD</sub> =9A, V <sub>GS</sub> =0V	--	--	1.3	V
t <sub>rr</sub>	Reverse Recovery Time	T <sub>j</sub> =25°C, I <sub>sd</sub> =9A, V <sub>GS</sub> =0V	--	28	--	nS
Q <sub>rr</sub>	Reverse Recovery Charge	di/dt=100A/μs		16	--	nC

NOTE:

- ① Pulse width ≤ 300μs; duty cycles ≤ 2%.  
 ② Pulse width limited by max. junction temperature.

Typical Characteristics

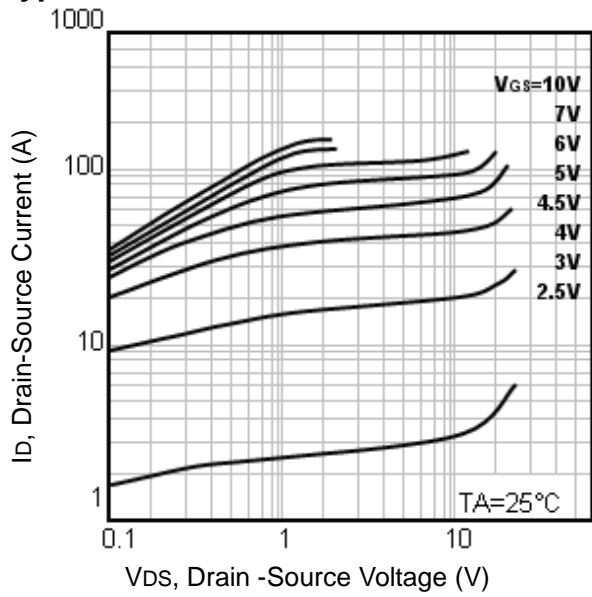

Fig1. Typical Output Characteristics

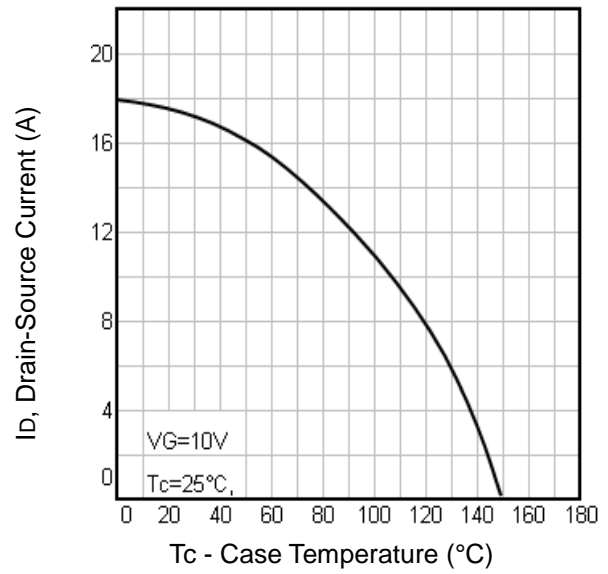

Fig2. Maximum Drain Current Vs. Case Temperature

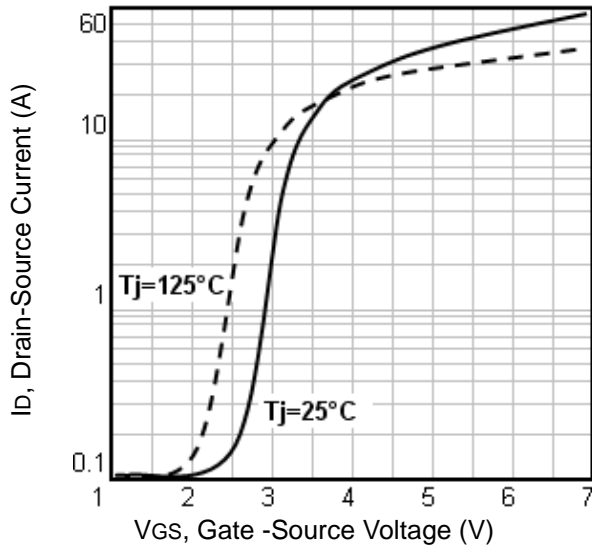

Fig3. Typical Transfer Characteristics

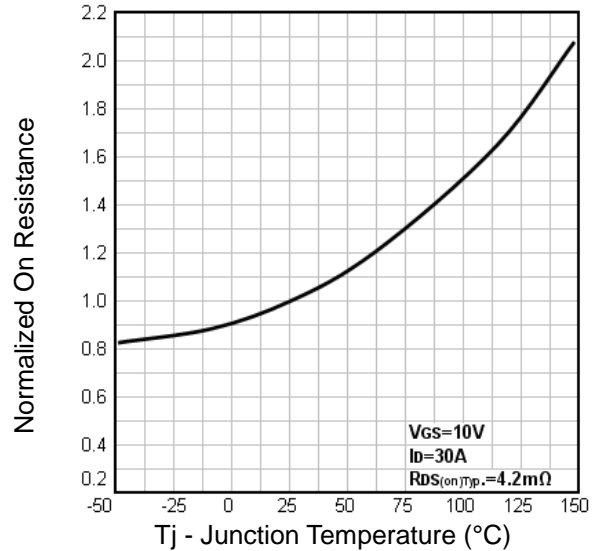

Fig4. Normalized On-Resistance Vs. Temperature

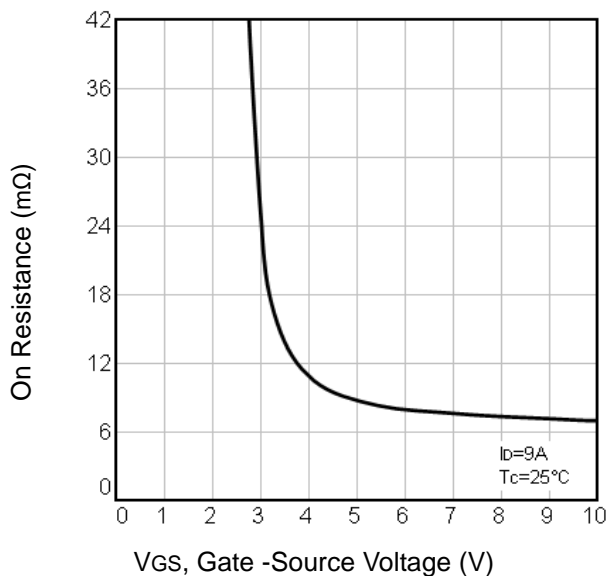

Fig5. On Resistance Vs. Gate-Source Voltage

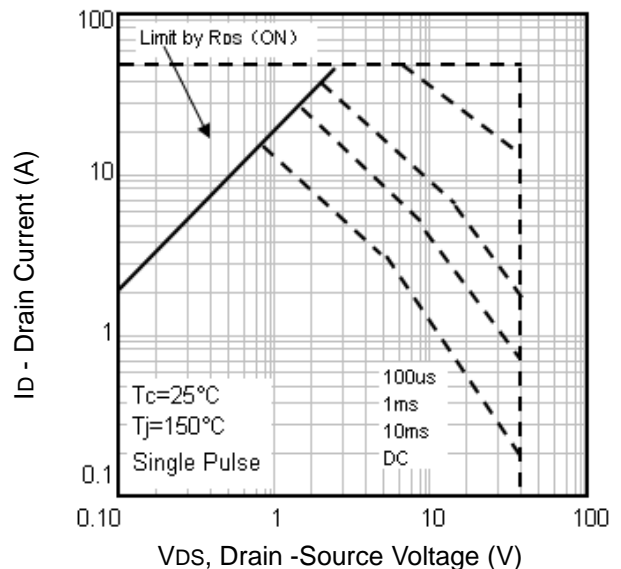

Fig6. Maximum Safe Operating Area

Typical Characteristics

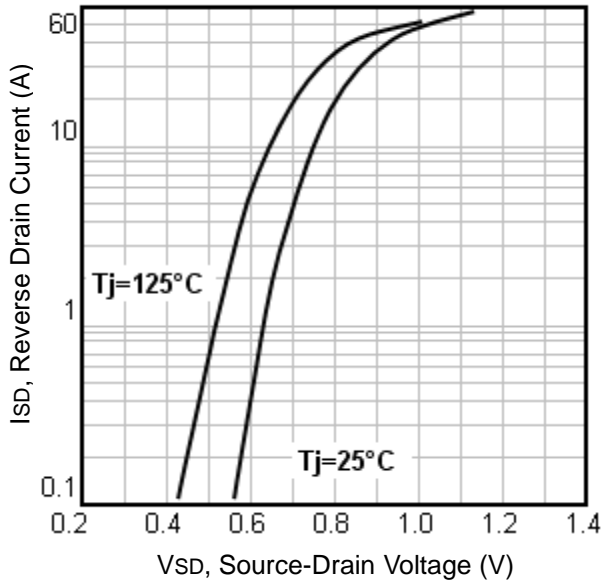

Fig7. Typical Source-Drain Diode Forward Voltage

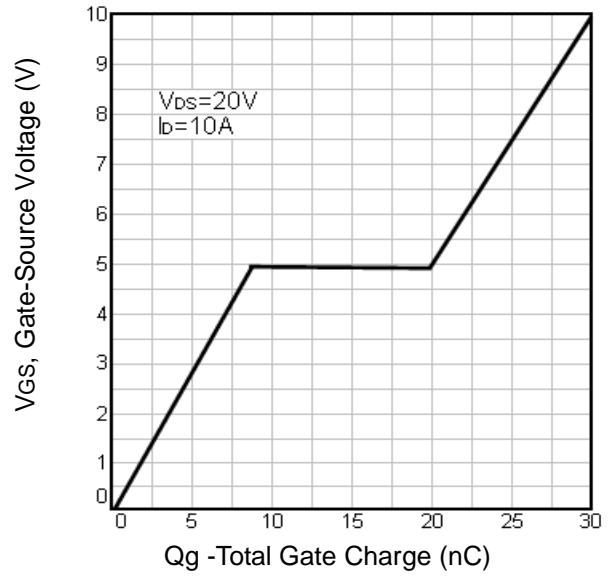

Fig8. Typical Gate Charge Vs. Gate-Source Voltage

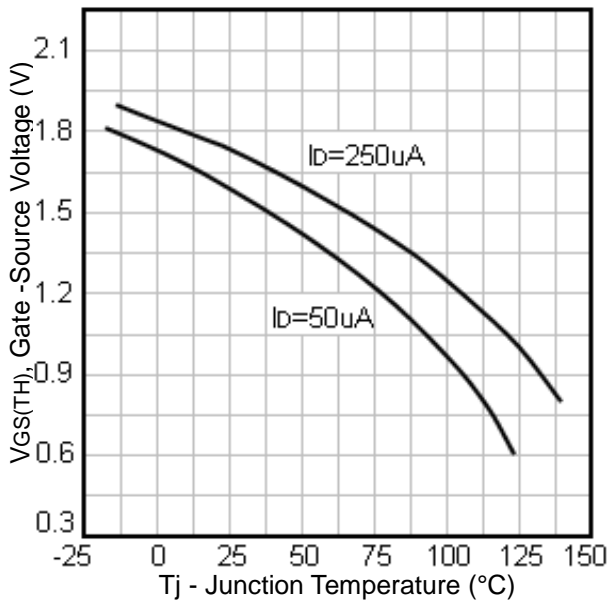

Fig9. Threshold Voltage Vs. Temperature

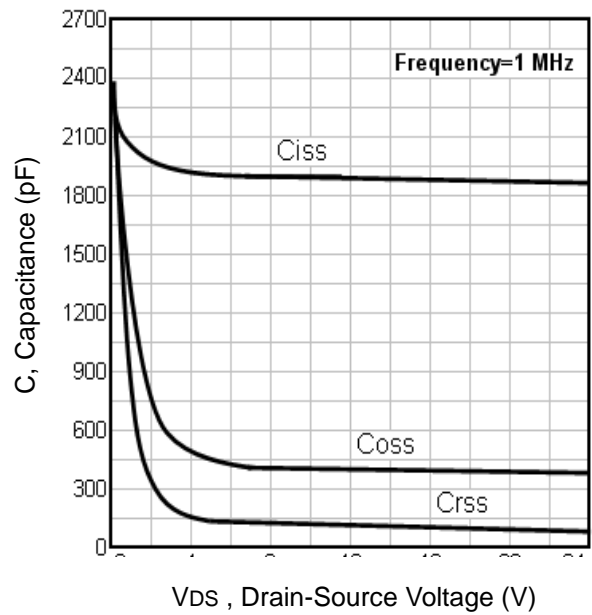

Fig10. Typical Capacitance Vs. Drain-Source Voltage

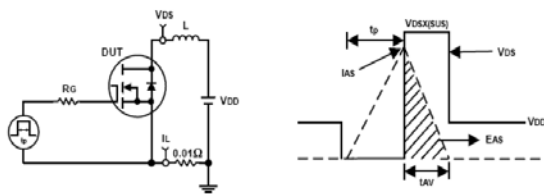

Fig11. Unclamped Inductive Test Circuit and waveforms

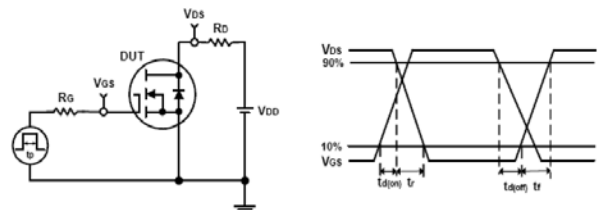
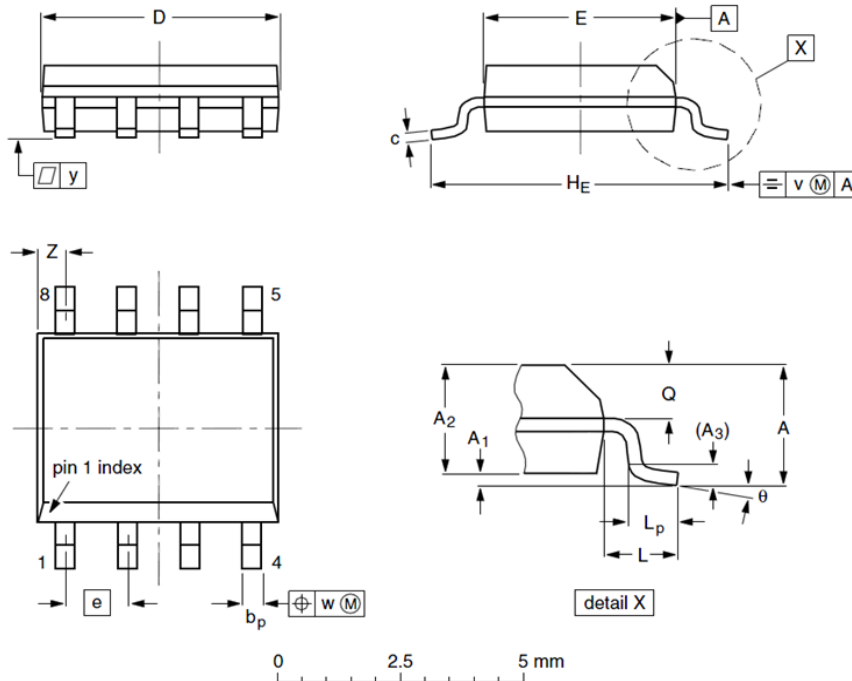

Fig12. Switching Time Test Circuit and waveforms

### SOP8 Package Outline Data



Label	Dimensions (unit: mm)		
	Min	Typ	Max
A	--	--	1.75
A <sub>1</sub>	0.10	0.18	0.25
A <sub>2</sub>	1.25	1.35	1.50
A <sub>3</sub>	--	0.25	--
b <sub>p</sub>	0.36	0.42	0.51
c	0.19	0.22	0.25
D	4.80	4.92	5.00
E	3.80	3.90	4.00
e	--	1.27	--
H <sub>E</sub>	5.80	6.00	6.20
L	--	1.05	--
L <sub>p</sub>	0.40	0.68	1.00
Q	0.60	0.65	0.725
v	--	0.25	--
w	--	0.25	--
y	--	0.10	--
Z	0.30	0.50	0.70
θ	0°		8°

#### Notes:

1. Follow JEDEC MS-012.
2. Dimension "D" does NOT include mold flash, protrusions or gate burrs. Mold flash, protrusions or gate burrs shall not exceed 0.15mm per side.
3. Dimension "E" does NOT include interlead flash or protrusion. Interlead flash or protrusion shall not exceed 0.25mm per side.
4. Dimension "b<sub>p</sub>" does NOT include dambar protrusion. Allowable dambar protrusion shall be 0.1mm total in excess of "b<sub>p</sub>" dimension at maximum material condition. The dambar cannot be located on the lower radius of the foot.

### Customer Service

#### Sales and Service:

[sales@vgsemi.com](mailto:sales@vgsemi.com)

**Vanguard Semiconductor CO., LTD**

**TEL:** (86-755) -26902410

**FAX:** (86-755) -26907027

**WEB:** [www.vgsemi.com](http://www.vgsemi.com)